

HOT SWAPPABLE 2-WIRE BUS BUFFERS

FEATURES

- Operating Power-Supply Voltage Range of 2.7-V to 5.5-V
- Supports Bidirectional Data Transfer of I²C Bus Signals
- SDA and SCL Lines Are Buffered Which Increases Fanout
- 1-V Precharge on All SDA and SCL Lines Prevents Corruption During Live Board Insertion and Removal From Backplane
- SDA and SCL Input Lines Are Isolated From Outputs
- Accommodates Standard Mode and Fast Mode I²C Devices
- Applications Include Hot Board Insertion and Bus Extension
- Low I_{CC} Chip Disable of <1 μA
- READY Open-Drain Output
- Supports Clock Stretching, Arbitration, and Synchronization
- Powered-Off High-Impedance I²C Pins
- Open-Drain I²C Pins
- Latch-Up Performance Exceeds 100 mA Per JESD 78, Class II
- ESD Protection Exceeds JESD 22
 - 8000-V Human-Body Model (A114-A)
 - 200-V Machine Model (A115-A)
 - 1000-V Charged-Device Model (C101)

D OR DGK PACKAGES
(TOP VIEW)

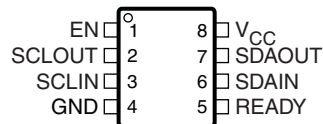

DESCRIPTION/ORDERING INFORMATION

The TCA4311 is a hot swappable I²C bus buffer that supports I/O card insertion into a live backplane without corruption of the data and clock busses. Control circuitry prevents the backplane from being connected to the card until a stop command or bus idle occurs on the backplane without bus contention on the card. When the connection is made, this device provides bidirectional buffering, keeping the backplane and card capacitances isolated. During insertion, the SDA and SCL lines are precharged to 1 V to minimize the current required to charge the parasitic capacitance of the chip.

When the I²C bus is idle, the TCA4311 can be put into shutdown mode by setting the EN pin low. When EN is high, the TCA4311 resumes normal operation. It also includes an open drain READY output pin, which indicates that the backplane and card sides are connected together. When READY is high, the SDAIN and SCLIN are connected to SDAOUT and SCLOUT. When the two sides are disconnected, READY is low.

Both the backplane and card may be powered with supply voltages ranging from 2.7 V to 5.5 V, with no restrictions on which supply voltage is higher.

The TCA4311 has standard open-drain I/Os. The size of the pullup resistors to the I/Os depends on the system, but each side of this buffer must have a pullup resistor. The device is designed to work with Standard Mode and Fast Mode I²C devices in addition to SMBus devices. Standard Mode I²C devices only specify 3 mA in a generic I²C system where Standard Mode devices and multiple masters are possible. Under certain conditions, high termination currents can be used.



Please be aware that an important notice concerning availability, standard warranty, and use in critical applications of Texas Instruments semiconductor products and disclaimers thereto appears at the end of this data sheet.

CompactPCI is a trademark of PCI Industrial Computer Manufacturers Group.

ORDERING INFORMATION

T _A	PACKAGE ⁽¹⁾⁽²⁾		ORDERABLE PART NUMBER	TOP-SIDE MARKING
–40°C to 85°C	SOIC – D	Tube	TCA4311D	PR311
		Tape and reel	TCA4311DR	PR311
	MSOP – DGK	Tape and reel	TCA4311DGKR	3JS

(1) Package drawings, thermal data, and symbolization are available at www.ti.com/packaging.

(2) For the most current package and ordering information, see the Package Option Addendum at the end of this document, or see the TI website at www.ti.com.

TERMINAL FUNCTIONS

SOIC (D) OR MSOP (DGK) PACKAGE		DESCRIPTION
PIN NUMBER	NAME	
1	EN	Active-high chip enable pin. If EN is low, the TCA4311 is in a low current (<1 μ A) mode. It also disables the rise-time accelerators, disables the bus precharge circuitry, drives READY low, isolates SDAIN from SDAOUT and isolates SCLIN from SCLOUT. EN should be high (at V _{CC}) for normal operation. Connect EN to V _{CC} if this feature is not being used.
2	SCLOUT	Serial clock output. Connect this pin to the SCL bus on the card.
3	SCLIN	Serial clock input. Connect this pin to the SCL bus on the backplane.
4	GND	Supply ground
5	READY	Connection flag/rise-time accelerator control. READY is low when either EN is low or the start-up sequence described in the operation section has not been completed. READY goes high when EN is high and start-up is complete. Connect a 10-k Ω resistor from this pin to V _{CC} to provide the pull up.
6	SDAIN	Serial data input. Connect this pin to the SDA bus on the backplane.
7	SDAOUT	Serial data output. Connect this pin to the SDA bus on the card.
8	V _{CC}	Supply power. Main input power supply from backplane. This is the supply voltage for the devices on the backplane I ² C busses. Connect pullup resistors from SDAIN and SCLIN (and also from SDAOUT and SCLOUT) to this pin. Place a bypass capacitor of at least 0.01 μ F close to this pin for best results.

BLOCK DIAGRAM

2-Wire Bus Buffer and Hot Swap Controller

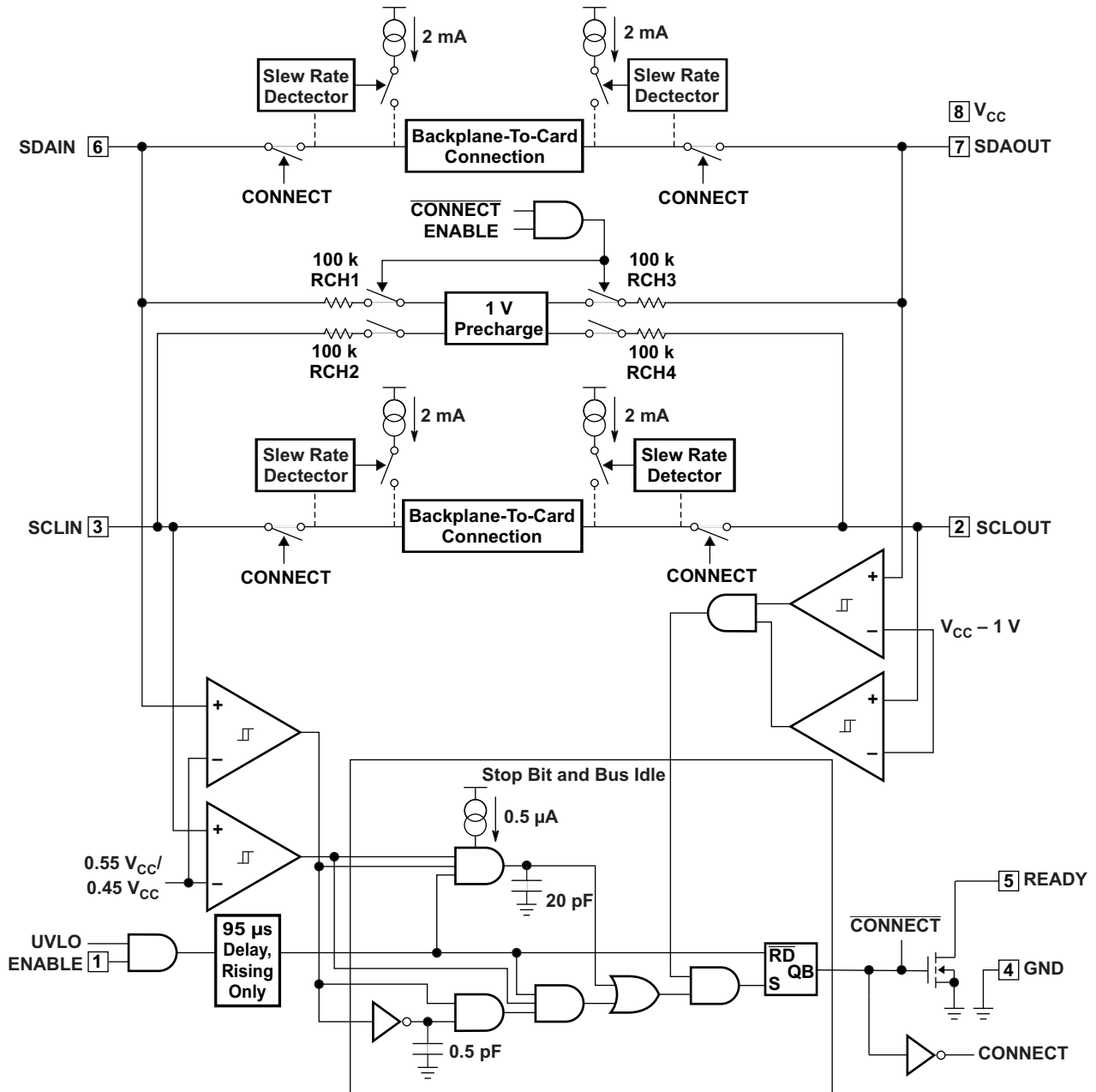

ABSOLUTE MAXIMUM RATINGS⁽¹⁾

over operating free-air temperature range (unless otherwise noted)

		MIN	MAX	UNIT
V_{CC}	Supply voltage range	-0.5	7	V
$V_{I/O}$	I ² C bus voltage range ⁽²⁾	SDAIN, SCLIN, SDAOUT, SCLOUT		V
V_I	Input voltage range ⁽²⁾	EN		V
I_{IK}	Input clamp current	$V_I < 0$		mA
I_{OK}	Output clamp current	$V_O < 0$		mA
I_O	Continuous output current	±50		mA
I_{CC}	Continuous current through V_{CC} or GND	±100		mA
θ_{JA}	Package thermal impedance ⁽³⁾	D package		97
		DGK package		172
T_{stg}	Storage temperature range	-65	150	°C

- (1) Stresses beyond those listed under "absolute maximum ratings" may cause permanent damage to the device. These are stress ratings only, and functional operation of the device at these or any other conditions beyond those indicated under "recommended operating conditions" is not implied. Exposure to absolute-maximum-rated conditions for extended periods may affect device reliability.
- (2) The input negative-voltage and output voltage ratings may be exceeded if the input and output current ratings are observed.
- (3) The package thermal impedance is calculated in accordance with JESD 51-7.

RECOMMENDED OPERATING CONDITIONS

		MIN	MAX	UNIT
V_{CC}	Supply voltage	2.7	5.5	V
V_{IH}	High-level input voltage	SDA and SCL inputs		$0.7 \times V_{CC}$
		EN input		2
V_{IL}	Low-level input voltage	SDA and SCL inputs		-0.5 $0.3 \times V_{CC}$
		EN input		-0.5 0.8
I_{OL}	Low-level output current	$V_{CC} = 3$ V		3
		$V_{CC} = 4.5$ V		3
T_A	Operating free-air temperature	-40	85	°C

ELECTRICAL CHARACTERISTICS

over operating free-air temperature range (unless otherwise noted)

PARAMETER		TEST CONDITIONS	MIN	TYP	MAX	UNIT
Power Supply						
V_{CC}	Positive supply voltage		2.7		5.5	V
I_{CC}	Supply current	$V_{CC} = 5.5\text{ V}$, $V_{SDAIN} = V_{SCLIN} = 0\text{ V}$		5.1	7	mA
I_{SD}	Supply current in shutdown mode	$V_{EN} = 0\text{ V}$		0.1		μA
Start-Up Circuitry						
V_{PRE}	Precharge voltage	SDA, SCL floating	0.8	1	1.2	V
t_{IDLE}	Bus idle time		50	95	150	μs
V_{EN}	EN threshold voltage			$0.5 \times V_{CC}$	$0.9 \times V_{CC}$	V
V_{DIS}	Disable threshold voltage	EN Pin	$0.1 \times V_{CC}$	$0.5 \times V_{CC}$		V
I_{EN}	EN input current	EN from 0 V to V_{CC}		± 0.1	± 1	μA
t_{EN}	Enable time			95		μs
t_{DIS}	Disable time (EN to READY)			30		ns
t_{STOP}	SDAIN to READY delay after STOP			1.2		μs
t_{READY}	SCLOUT/SDAOUT to READY			0.8		μs
I_{OFF}	READY OFF state leakage current			± 0.1		μA
V_{OL}	READY output low voltage	$I_{PULLUP} = 3\text{ mA}$			0.4	V
Rise-Time Accelerators						
$I_{PULLUPAC}$	Transient boosted pull-up current	Positive transition on SDA, SCL, $V_{CC} = 2.7\text{ V}$,	1	2		mA
Input-Output Connection						
V_{OS}	Input-output offset voltage	10 k Ω to V_{CC} on SDA, SCL, $V_{CC} = 3.3\text{ V}$, ⁽¹⁾	0	100	175	mV
C_{IN}	Digital input capacitance				10	pF
V_{OL}	Output low voltage, input = 0 V	SDA, SCL pins, $I_{SINK} = 3\text{ mA}$,	0		0.4	V
I_I	Input leakage current	SDA, SCL pins = $V_{CC} = 5.5\text{ V}$			± 5	μA

(1) The connection circuitry always regulates its output to a higher voltage than its input. The magnitude of this offset voltage as a function of the pullup resistor and V_{CC} voltage is shown in the Typical Performance Characteristics section.

OPERATION

Start-Up

When the TCA4311 first receives power on its V_{CC} pin, either during power-up or during live insertion, it starts in an undervoltage lockout (UVLO) state, ignoring any activity on the SDA and SCL pins until V_{CC} rises above 2.5 V.

During this time, the 1 V precharge circuitry is also active and forces 1 V through 100-k Ω nominal resistors to the SDA and SCL pins. Because the I/O card is being plugged into a live backplane, the voltage on the backplane SDA and SCL busses may be anywhere between 0 V and V_{CC} . Precharging the SCL and SDA pins to 1 V minimizes the worst-case voltage differential these pins will see at the moment of connection, therefore minimizing the amount of disturbance caused by the I/O card.

Once the TCA4311 comes out of UVLO, it assumes that SDAIN and SCLIN have been inserted into a live system and that SDAOUT and SCLOUT are being powered up at the same time as itself. Therefore, it looks for either a stop bit or bus idle condition on the backplane side to indicate the completion of a data transaction. When either one occurs, the part also verifies that both the SDAOUT and SCLOUT voltages are high. When all of these conditions are met, the input-to-output connection circuitry is activated, joining the SDA and SCL busses on the I/O card with those on the backplane, and the rise time accelerators are enabled.

Connection Circuitry

Once the connection circuitry is activated, the functionality of the SDAIN and SDAOUT pins is identical. A low forced on either pin at any time results in both pin voltages being low. For proper operation, logic low input voltages should be no higher than 0.4 V with respect to the ground pin voltage of the TCA4311. SDAIN and SDAOUT enter a logic high state only when all devices on both SDAIN and SDAOUT release high. The same is true for SCLIN and SCLOUT. This important feature ensures that clock stretching, clock synchronization, arbitration and the acknowledge protocol always work, regardless of how the devices in the system are tied to the TCA4311.

Another key feature of the connection circuitry is that it provides bidirectional buffering, keeping the backplane and card capacitances isolated. Because of this isolation, the waveforms on the backplane busses look slightly different than the corresponding card bus waveforms, as described here.

Input to Output Offset Voltage

When a logic low voltage, V_{LOW1} , is driven on any of the TCA4311's data or clock pins, the TCA4311 regulates the voltage on the other side of the chip (call it V_{LOW2}) to a slightly higher voltage, as directed by the following equation:

$$V_{LOW2} = V_{LOW1} + 75 \text{ mV} + (V_{CC}/R) \times 100$$

where R is the bus pullup resistance in ohms (Ω). For example, if a device is forcing SDAOUT to 10 mV where $V_{CC} = 3.3$ V and the pullup resistor R on SDAIN is 10 k Ω , then the voltage on SDAIN = $10 + 75 + (3.3/10000) \times 100 = 118$ mV. See the *Typical Performance Characteristics* section for curves showing the offset voltage as a function of V_{CC} and R.

Propagation Delays

During a rising edge, the rise-time on each side is determined by the combined pullup current of the TCA4311 boost current and the bus resistor and the equivalent capacitance on the line. If the pullup currents are the same, a difference in rise-time occurs which is directly proportional to the difference in capacitance between the two sides. This effect is displayed in [Figure 1](#) for $V_{CC} = 3.3$ V and a 10-k Ω pullup resistor on each side (50 pF on one side and 150 pF on the other). Since the output side has less capacitance than the input, it rises faster and the effective t_{PLH} is negative.

There is a finite propagation delay, t_{PHL} , through the connection circuitry for falling waveforms. [Figure 2](#) shows the falling edge waveforms for the same V_{CC} , pullup resistors and equivalent capacitance conditions as used in [Figure 1](#). An external NMOS device pulls down the voltage on the side with 150 pF capacitance; the TCA4311 pulls down the voltage on the opposite side, with a delay of 55 ns. This delay is always positive and is a function of supply voltage, temperature and the pullup resistors and equivalent bus capacitances on both sides of the bus. The *Typical Performance Characteristics* section shows t_{PHL} as a function of temperature and voltage for

10-k Ω pullup resistors and 100 pF equivalent capacitance on both sides of the part. By comparison with Figure 2, the $V_{CC} = 3.3$ V curve shows that increasing the capacitance from 50 pF to 100 pF results in a t_{PHL} increase from 55 ns to 75 ns. Larger output capacitances translate to longer delays (up to 150 ns). Users must quantify the difference in propagation times for a rising edge versus a falling edge in their systems and adjust setup and hold times accordingly.

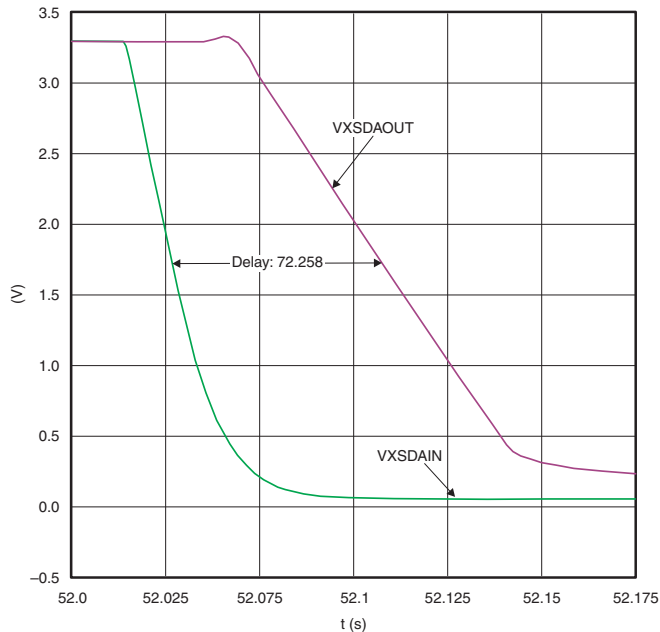

Figure 1. Input-Output Connection t_{pLH}

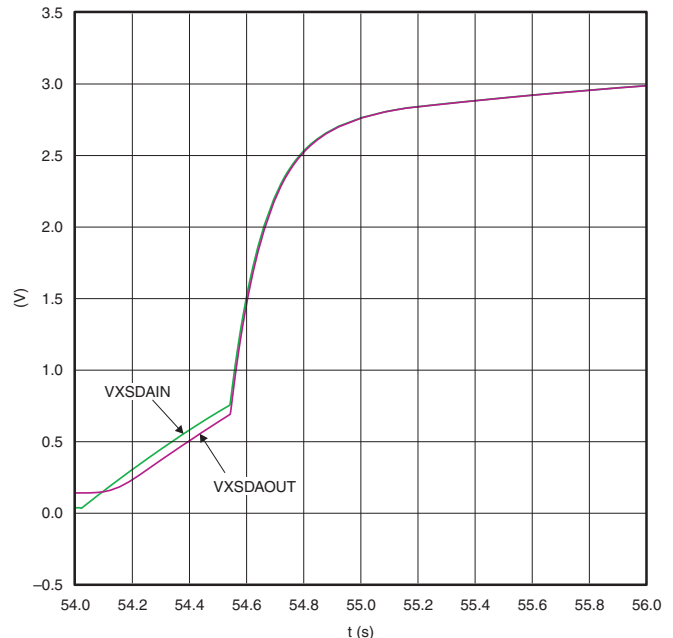

Figure 2. Input-Output Connection t_{pHL}

Rise-Time Accelerators

Once connection has been established, rise-time accelerator circuits on all four SDA and SCL pins are activated. These allow the user to choose weaker DC pullup currents on the bus, reducing power consumption while still meeting system rise-time requirements. During positive bus transitions, the TCA4311 switches in 2 mA (typical) of current to quickly slew the SDA and SCL lines once their DC voltages exceed 0.6 V. Using a general rule of 20 pF of capacitance for every device on the bus (10 pF for the device and 10 pF for interconnect), choose a pullup current so that the bus will rise on its own at a rate of at least 1.25 V/ μ s to guarantee activation of the accelerators.

For example, assume an SMBus system with $V_{CC} = 3$ V, a 10-k Ω pullup resistor and equivalent bus capacitance of 200 pF. The rise-time of an SMBus system is calculated from $(V_{IL(MAX)} - 0.15$ V) to $(V_{IH(MIN)} + 0.15$ V), or 0.65 V to 2.25 V. It takes an RC circuit 0.92 time constants to traverse this voltage for a 3 V supply; in this case, $0.92 \times (10$ k $\Omega \times 200$ pF) = 1.84 μ s. Thus, the system exceeds the maximum allowed rise-time of 1 μ s by 84%. However, using the rise-time accelerators, which are activated at a DC threshold of below 0.65 V, the worst-case rise-time is: $(2.25$ V – 0.65 V) \times 200 pF/1 mA = 320 ns, which meets the 1 μ s rise-time requirement.

READY Digital Output

This pin provides a digital flag which is low when either EN is low or the start-up sequence described earlier in this section has not been completed. READY goes high when EN is high and start-up is complete. The pin is driven by an open drain pull-down capable of sinking 3 mA while holding 0.4 V on the pin. Connect a resistor of 10 k Ω to V_{CC} to provide the pullup.

EN Low Current Disable

Grounding the EN pin disconnects the backplane side from the card side, disables the rise-time accelerators, drives READY low, disables the bus precharge circuitry and puts the part in a near-zero current state. When the pin voltage is driven all the way to V_{CC} , the part waits for data transactions on both the backplane and card sides to be complete (as described in the Start-Up section) before reconnecting the two sides.

Resistor Pull-Up Value Selection

The system pullup resistors must be strong enough to provide a positive slew rate of 1.25 V/μs on the SDA and SCL pins, in order to activate the boost pullup currents during rising edges. Choose maximum resistor value R using the formula:

$$R \leq (V_{CC(MIN)} - 0.6) (800,000) / C$$

where R is the pullup resistor value in ohms, $V_{CC(MIN)}$ is the minimum V_{CC} voltage and C is the equivalent bus capacitance in picofarads (pF).

In addition, regardless of the bus capacitance, always choose $R \leq 16 \text{ k}\Omega$ for $V_{CC} = 5.5 \text{ V}$ maximum, $R \leq 24 \text{ k}\Omega$ for $V_{CC} = 3.6 \text{ V}$ maximum. The start-up circuitry requires logic high voltages on SDAOUT and SCLOUT to connect the backplane to the card, and these pullup values are needed to overcome the precharge voltage.

Systems With Disparate Supply Voltages

In large 2-wire systems, the V_{CC} voltages seen by devices at various points in the system can differ by a few hundred millivolts or more. This situation is well modeled by a series resistor in the V_{CC} line, as shown in [Figure 15](#). For proper operation of the TCA4311, make sure that $V_{CC(BUS)} \geq V_{CC(TCA4311)} - 0.5 \text{ V}$.

TYPICAL PERFORMANCE CHARACTERISTICS

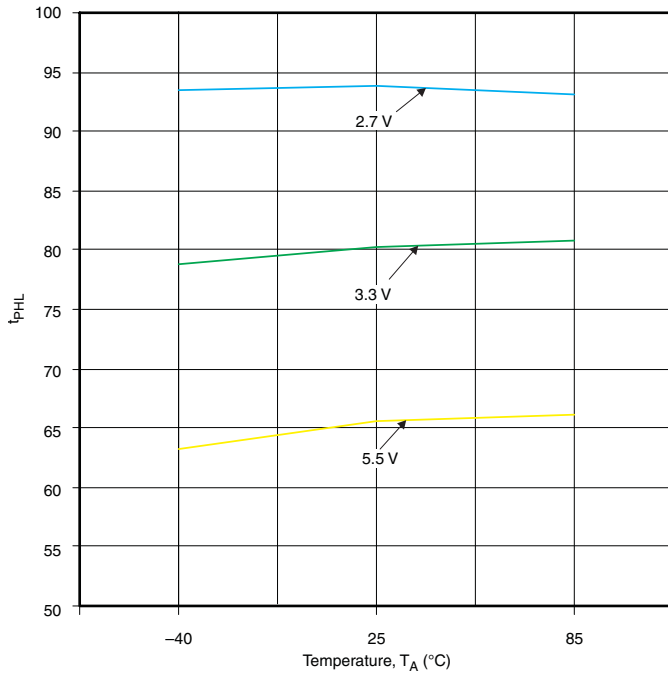

Figure 3. Input/Output t_{PLH} vs Temperature

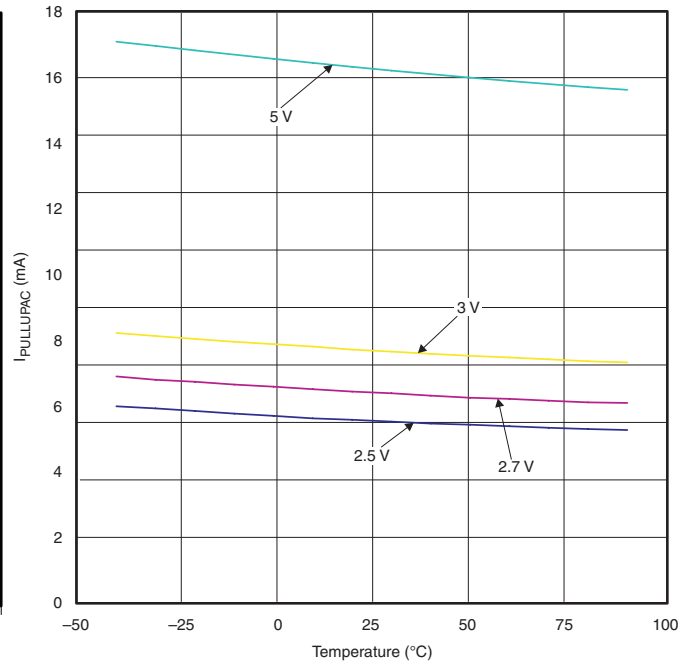

Figure 4. I_{PULLUPAC} vs Temperature

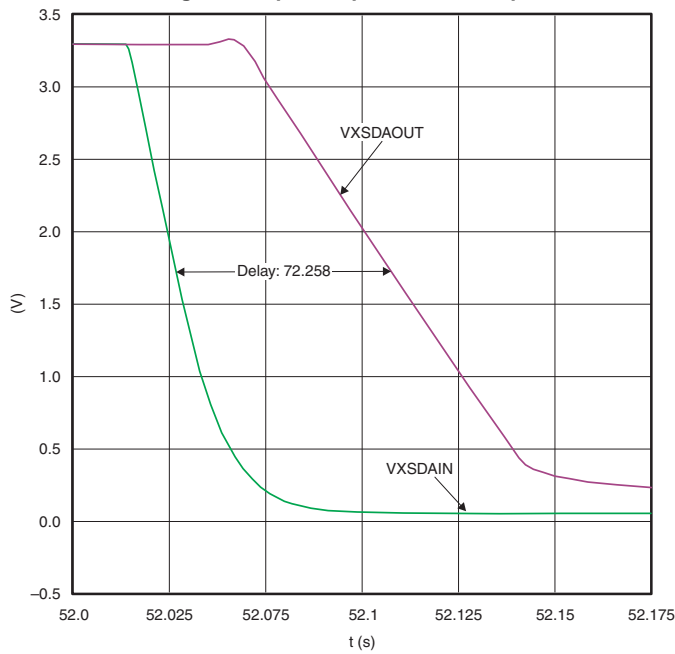

Figure 5.

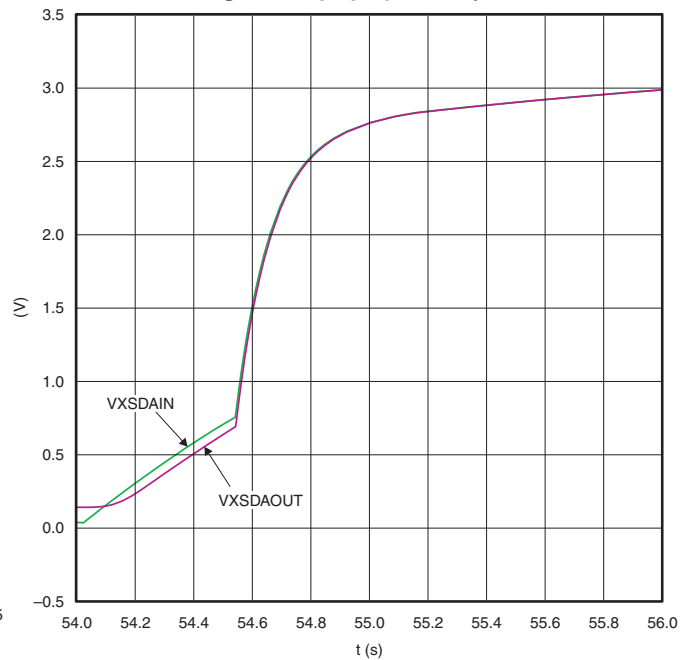

Figure 6.

TYPICAL PERFORMANCE CHARACTERISTICS (continued)

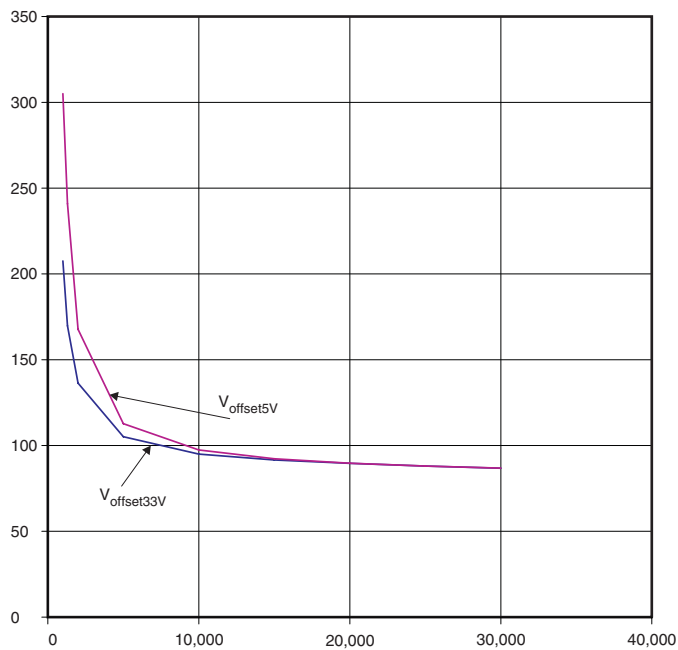
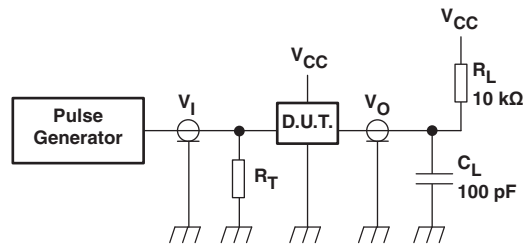

Figure 7.

PARAMETER MEASUREMENT INFORMATION



R_L = Load resistor

C_L = Load capacitance includes jig and probe capacitance

R_T = Termination resistance should be equal to the output impedance Z_0 of the pulse generators.

Figure 8. Test Circuitry for Switching Times

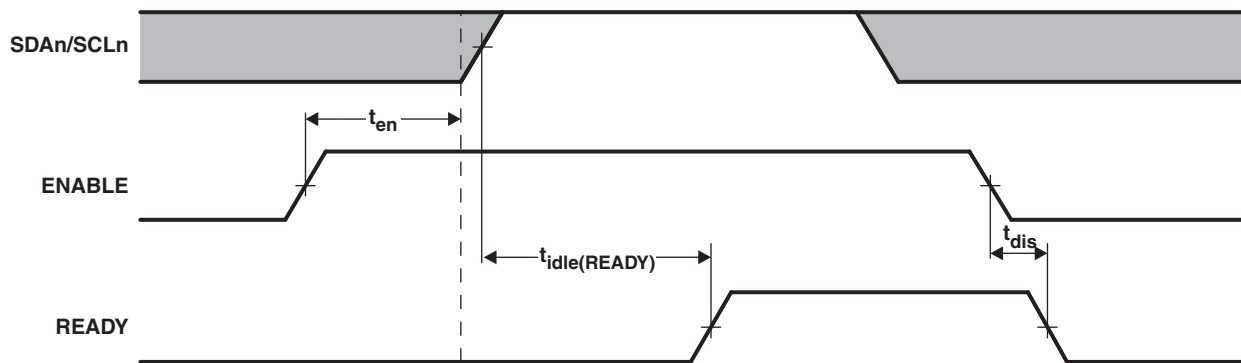

Figure 9. Timing for t_{en} , $t_{idle(READY)}$, and t_{dis}

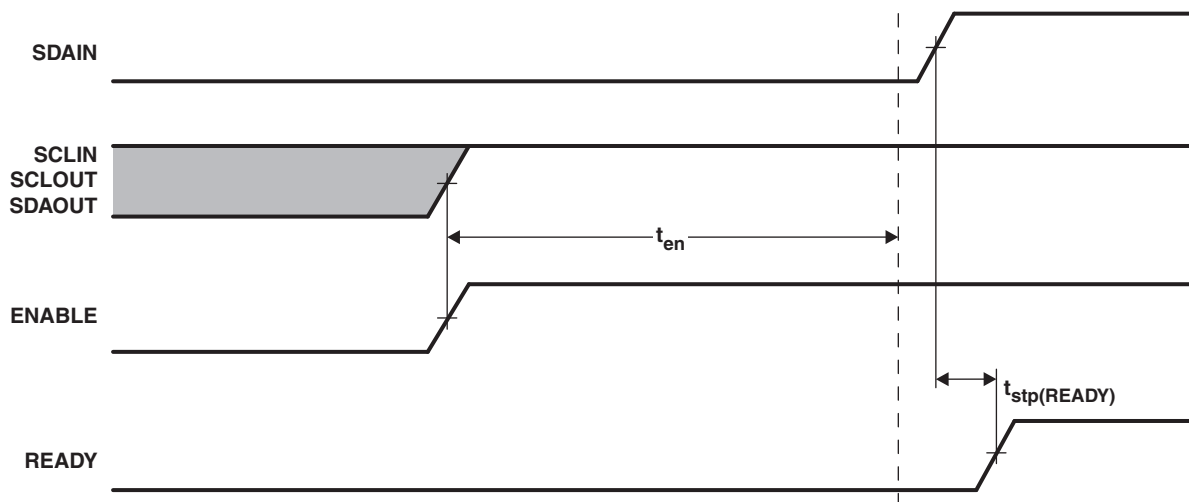

Figure 10. $t_{stp(READY)}$ That Can Occur After t_{en}

PARAMETER MEASUREMENT INFORMATION (continued)

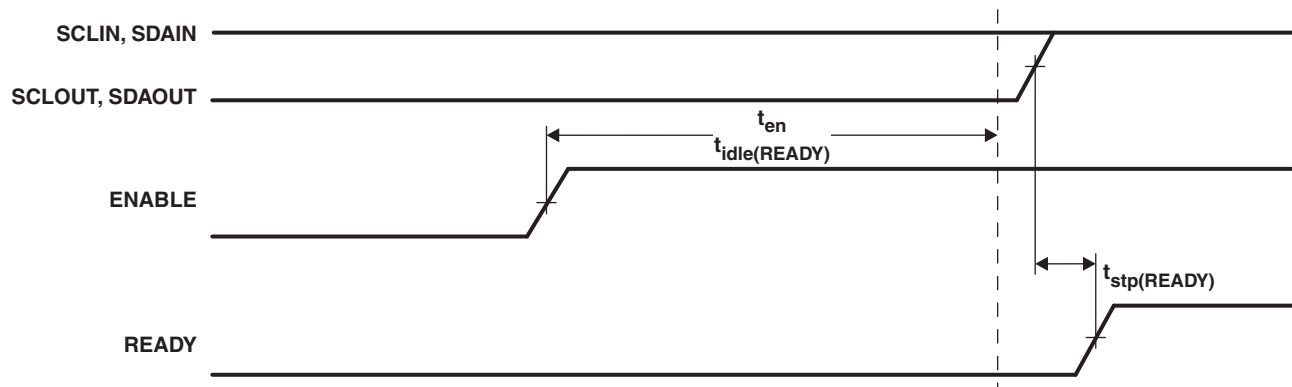

Figure 11. $t_{stp(READY)}$ That Can Occur After t_{en} and $t_{idle(READY)}$

APPLICATION INFORMATION

Live Insertion and Capacitance Buffering Application

Figure 12 through Figure 13 illustrate the usage of the TCA4311 in applications that take advantage of both its hot swap controlling and capacitance buffering features. In all of these applications, note that if the I/O cards were plugged directly into the backplane, all of the backplane and card capacitances would add directly together, making rise- and fall-time requirements difficult to meet. Placing a TCA4311 on the edge of each card, however, isolates the card capacitance from the backplane. For a given I/O card, the TCA4311 drives the capacitance of everything on the card and the backplane must drive only the capacitance of the TCA4311, which is less than 10 pF.

Figure 12 shows the TCA4311 in a CompactPCI™ configuration. Connect V_{CC} and EN to the output of one of the CompactPCI power supply Hot Swap circuits. Use a pullup resistor to EN for a card side enable/disable.

V_{CC} is monitored by a filtered UVLO circuit. With the V_{CC} voltage powering up after all other pins have established connection, the UVLO circuit ensures that the backplane and card data and clock busses are not connected until the transients associated with live insertion have settled. Owing to their small capacitance, the SDAIN and SCLIN pins cause minimal disturbance on the backplane busses when they make contact with the connector.

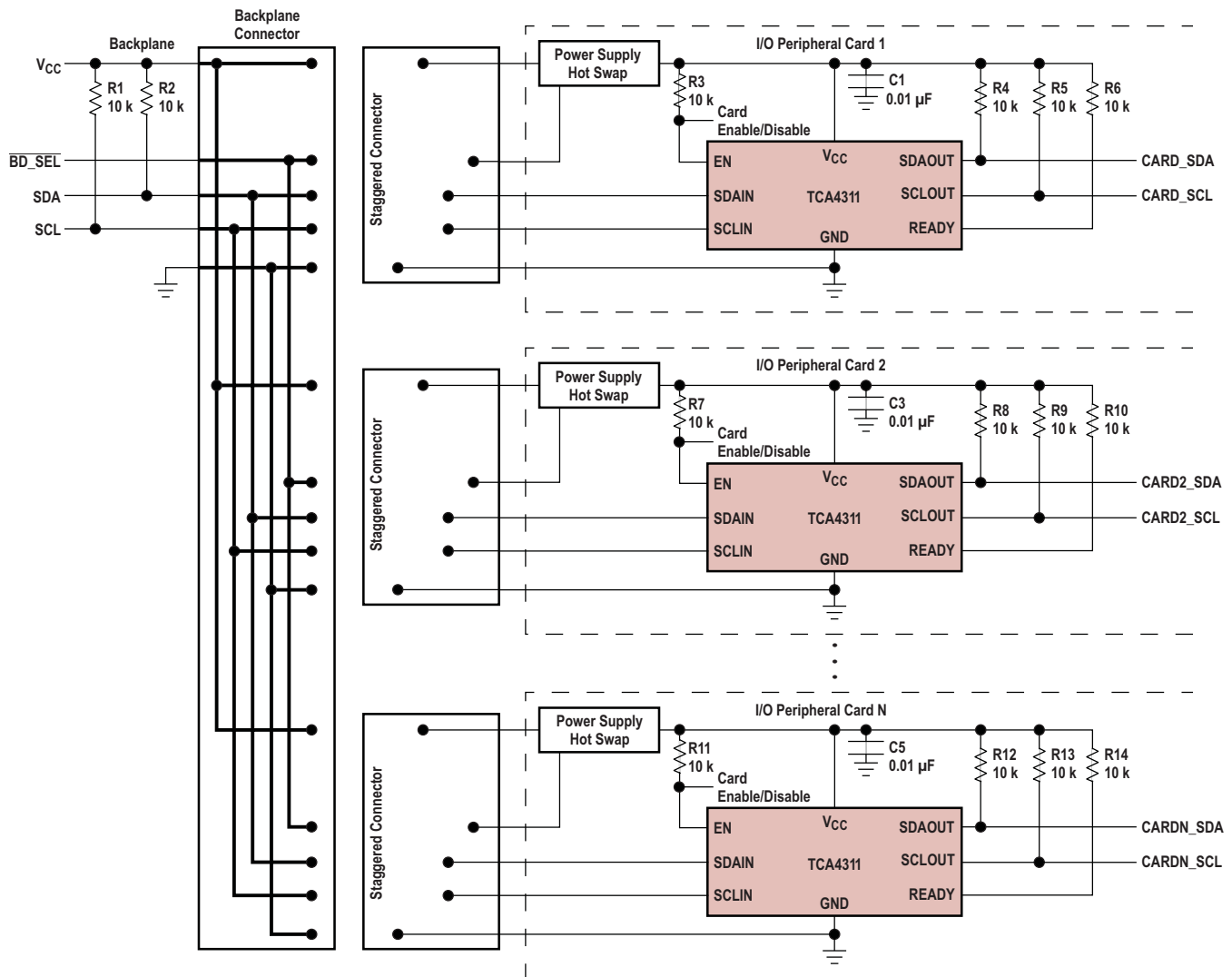

Figure 12. Inserting Multiple I/O Cards into a Live Backplane Using the TCA4311 in a CompactPCI System

Figure 13 shows the TCA4311 in a PCI application, where all of the pins have the same length. In this case, connect an RC series circuit on the I/O card between V_{CC} and EN. An RC product of 10 ms provides a filter to prevent the TCA4311 from becoming activated until the transients associated with live insertion have settled.

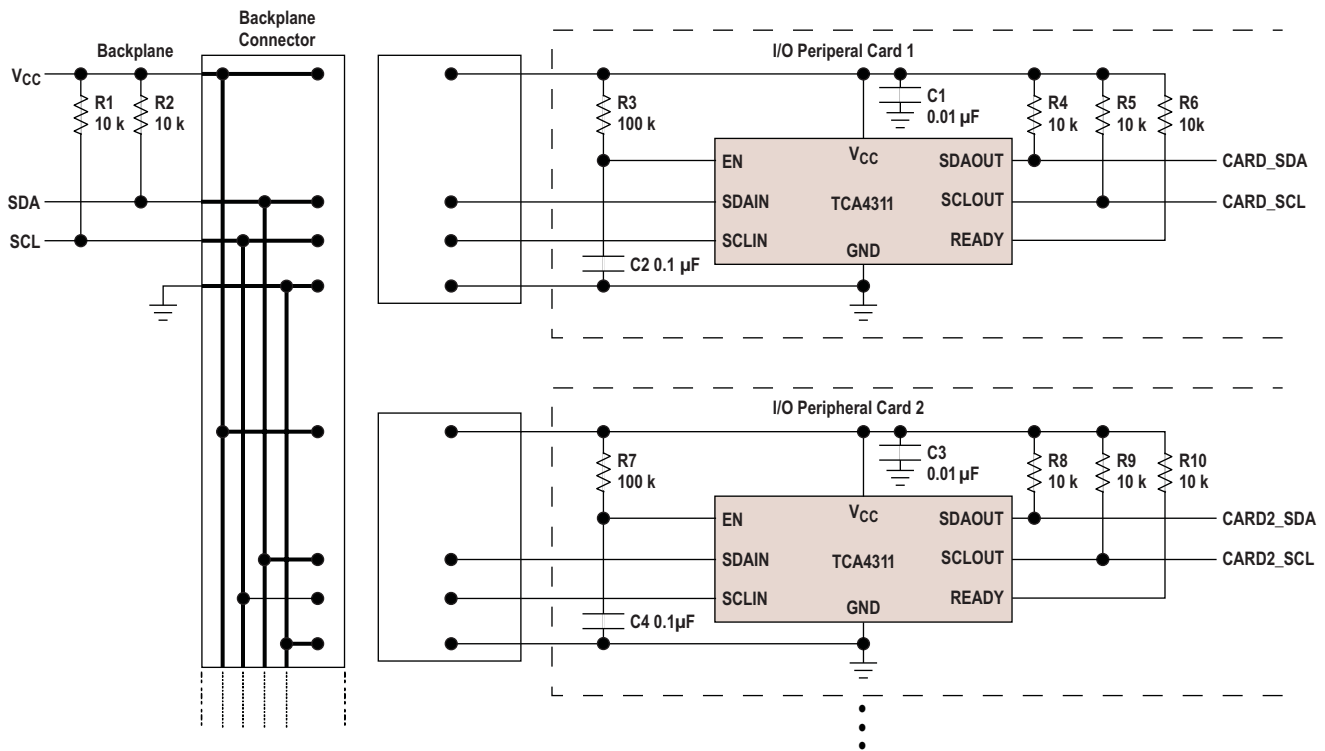

Figure 13. Inserting Multiple I/O Cards into a Live Backplane Using the TCA4311 in a PCI System

Repeater/Bus Extender Application

Users who wish to connect two 2-wire systems separated by a distance can do so by connecting two TCA4311 back-to-back, as shown in Figure 14. The I²C specification allows for 400 pF maximum bus capacitance, severely limiting the length of the bus. The SMBus specification places no restriction on bus capacitance, but the limited impedances of devices connected to the bus require systems to remain small if rise- and fall-time specifications are to be met. The strong pullup and pulldown impedances of the TCA4311 are capable of meeting rise- and fall-time specifications for one nanofarad of capacitance, thus allowing much more interconnect distance. In this situation, the differential ground voltage between the two systems may limit the allowed distance, because a valid logic low voltage with respect to the ground at one end of the system may violate the allowed V_{OL} specification with respect to the ground at the other end. In addition, the connection circuitry offset voltages of the back-to-back TCA4311 add together, directly contributing to the same problem.

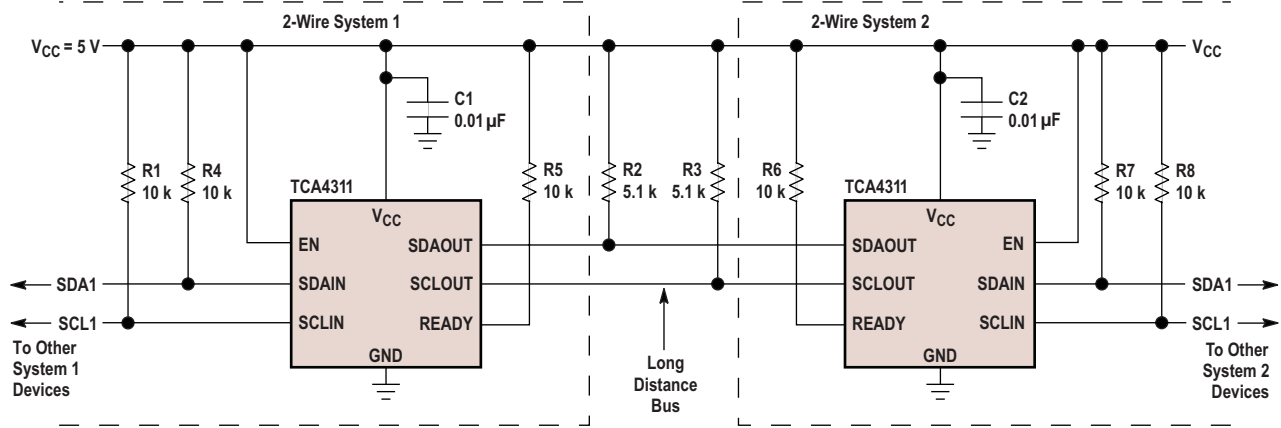

Figure 14. Repeater/Bus Extender Application

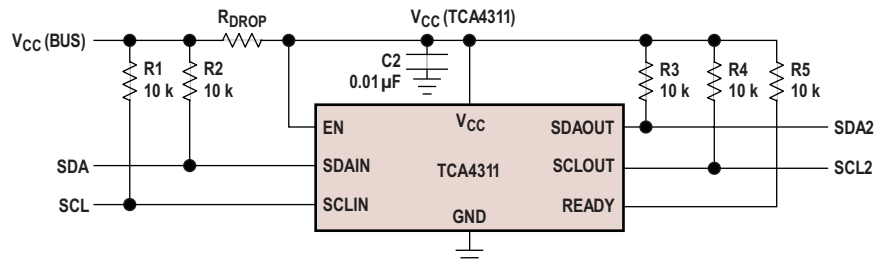
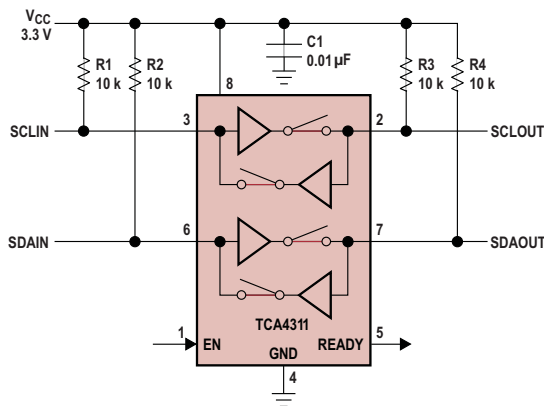
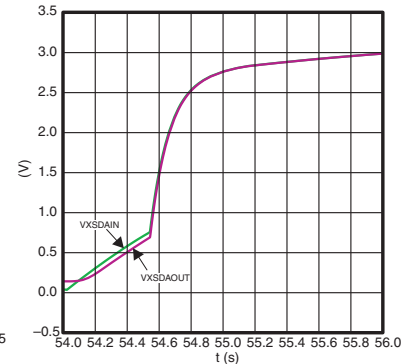
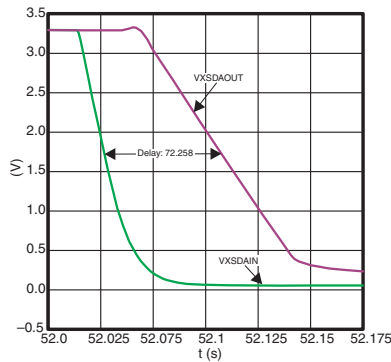

Figure 15. System With Disparate V_{CC} Voltages



Input – Output Connection t_{PLH}



PACKAGING INFORMATION

Orderable Device	Status ⁽¹⁾	Package Type	Package Drawing	Pins	Package Qty	Eco Plan ⁽²⁾	Lead/ Ball Finish	MSL Peak Temp ⁽³⁾	Samples (Requires Login)
TCA4311D	NRND	SOIC	D	8	75	Green (RoHS & no Sb/Br)	CU NIPDAU	Level-1-260C-UNLIM	
TCA4311DG4	NRND	SOIC	D	8	75	Green (RoHS & no Sb/Br)	CU NIPDAU	Level-1-260C-UNLIM	
TCA4311DGKR	NRND	MSOP	DGK	8	2500	Green (RoHS & no Sb/Br)	CU NIPDAU	Level-1-260C-UNLIM	
TCA4311DGKRG4	NRND	MSOP	DGK	8	2500	Green (RoHS & no Sb/Br)	CU NIPDAU	Level-1-260C-UNLIM	
TCA4311DR	NRND	SOIC	D	8	2500	Green (RoHS & no Sb/Br)	CU NIPDAU	Level-1-260C-UNLIM	
TCA4311DRG4	NRND	SOIC	D	8	2500	Green (RoHS & no Sb/Br)	CU NIPDAU	Level-1-260C-UNLIM	

⁽¹⁾ The marketing status values are defined as follows:

ACTIVE: Product device recommended for new designs.

LIFEBUY: TI has announced that the device will be discontinued, and a lifetime-buy period is in effect.

NRND: Not recommended for new designs. Device is in production to support existing customers, but TI does not recommend using this part in a new design.

PREVIEW: Device has been announced but is not in production. Samples may or may not be available.

OBSELETE: TI has discontinued the production of the device.

⁽²⁾ Eco Plan - The planned eco-friendly classification: Pb-Free (RoHS), Pb-Free (RoHS Exempt), or Green (RoHS & no Sb/Br) - please check <http://www.ti.com/productcontent> for the latest availability information and additional product content details.

TBD: The Pb-Free/Green conversion plan has not been defined.

Pb-Free (RoHS): TI's terms "Lead-Free" or "Pb-Free" mean semiconductor products that are compatible with the current RoHS requirements for all 6 substances, including the requirement that lead not exceed 0.1% by weight in homogeneous materials. Where designed to be soldered at high temperatures, TI Pb-Free products are suitable for use in specified lead-free processes.

Pb-Free (RoHS Exempt): This component has a RoHS exemption for either 1) lead-based flip-chip solder bumps used between the die and package, or 2) lead-based die adhesive used between the die and leadframe. The component is otherwise considered Pb-Free (RoHS compatible) as defined above.

Green (RoHS & no Sb/Br): TI defines "Green" to mean Pb-Free (RoHS compatible), and free of Bromine (Br) and Antimony (Sb) based flame retardants (Br or Sb do not exceed 0.1% by weight in homogeneous material)

⁽³⁾ MSL, Peak Temp. -- The Moisture Sensitivity Level rating according to the JEDEC industry standard classifications, and peak solder temperature.

Important Information and Disclaimer: The information provided on this page represents TI's knowledge and belief as of the date that it is provided. TI bases its knowledge and belief on information provided by third parties, and makes no representation or warranty as to the accuracy of such information. Efforts are underway to better integrate information from third parties. TI has taken and continues to take reasonable steps to provide representative and accurate information but may not have conducted destructive testing or chemical analysis on incoming materials and chemicals. TI and TI suppliers consider certain information to be proprietary, and thus CAS numbers and other limited information may not be available for release.

In no event shall TI's liability arising out of such information exceed the total purchase price of the TI part(s) at issue in this document sold by TI to Customer on an annual basis.

TAPE AND REEL INFORMATION

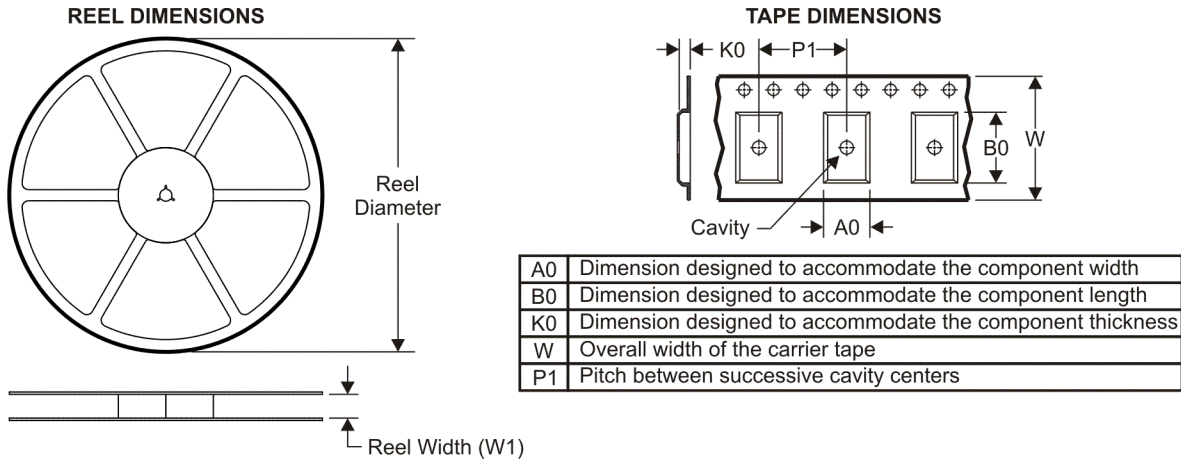

QUADRANT ASSIGNMENTS FOR PIN 1 ORIENTATION IN TAPE

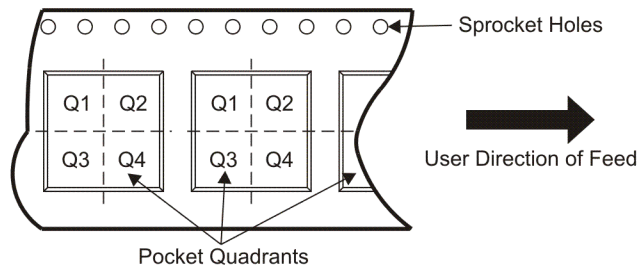

*All dimensions are nominal

Device	Package Type	Package Drawing	Pins	SPQ	Reel Diameter (mm)	Reel Width W1 (mm)	A0 (mm)	B0 (mm)	K0 (mm)	P1 (mm)	W (mm)	Pin1 Quadrant
TCA4311DGKR	MSOP	DGK	8	2500	330.0	12.4	5.3	3.4	1.4	8.0	12.0	Q1
TCA4311DR	SOIC	D	8	2500	330.0	12.4	6.4	5.2	2.1	8.0	12.0	Q1

TAPE AND REEL BOX DIMENSIONS

*All dimensions are nominal

Device	Package Type	Package Drawing	Pins	SPQ	Length (mm)	Width (mm)	Height (mm)
TCA4311DGKR	MSOP	DGK	8	2500	358.0	335.0	35.0
TCA4311DR	SOIC	D	8	2500	346.0	346.0	29.0

DGK (S-PDSO-G8)

PLASTIC SMALL-OUTLINE PACKAGE



- NOTES:
- A. All linear dimensions are in millimeters.
 - B. This drawing is subject to change without notice.
 - C. Body length does not include mold flash, protrusions, or gate burrs. Mold flash, protrusions, or gate burrs shall not exceed 0.15 per end.
 - D. Body width does not include interlead flash. Interlead flash shall not exceed 0.50 per side.
 - E. Falls within JEDEC MO-187 variation AA, except interlead flash.

D (R-PDSO-G8)

PLASTIC SMALL OUTLINE

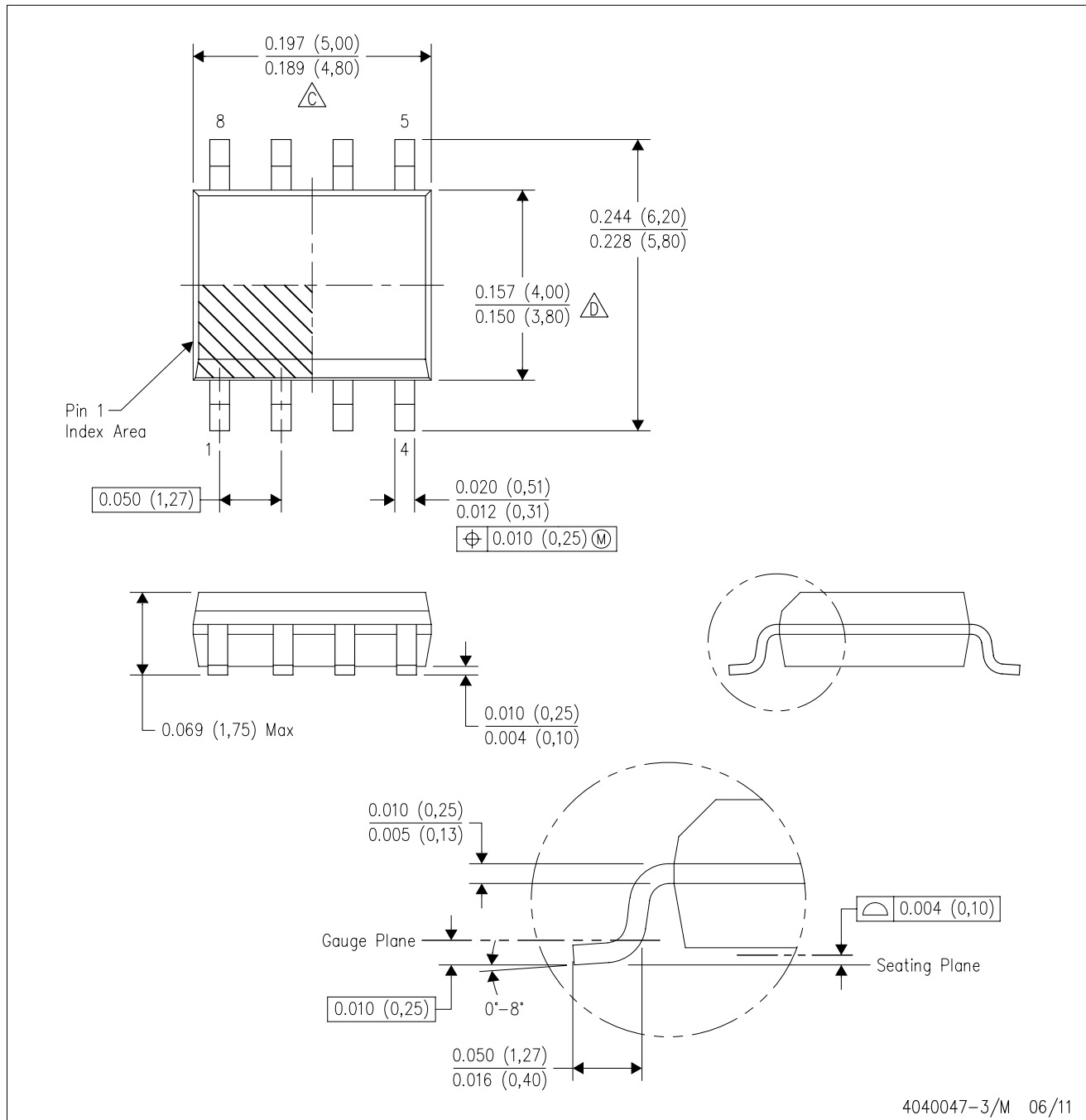

- NOTES:
- A. All linear dimensions are in inches (millimeters).
 - B. This drawing is subject to change without notice.
 - $\triangle C$ Body length does not include mold flash, protrusions, or gate burrs. Mold flash, protrusions, or gate burrs shall not exceed 0.006 (0,15) each side.
 - $\triangle D$ Body width does not include interlead flash. Interlead flash shall not exceed 0.017 (0,43) each side.
 - E. Reference JEDEC MS-012 variation AA.

D (R-PDSO-G8)

PLASTIC SMALL OUTLINE

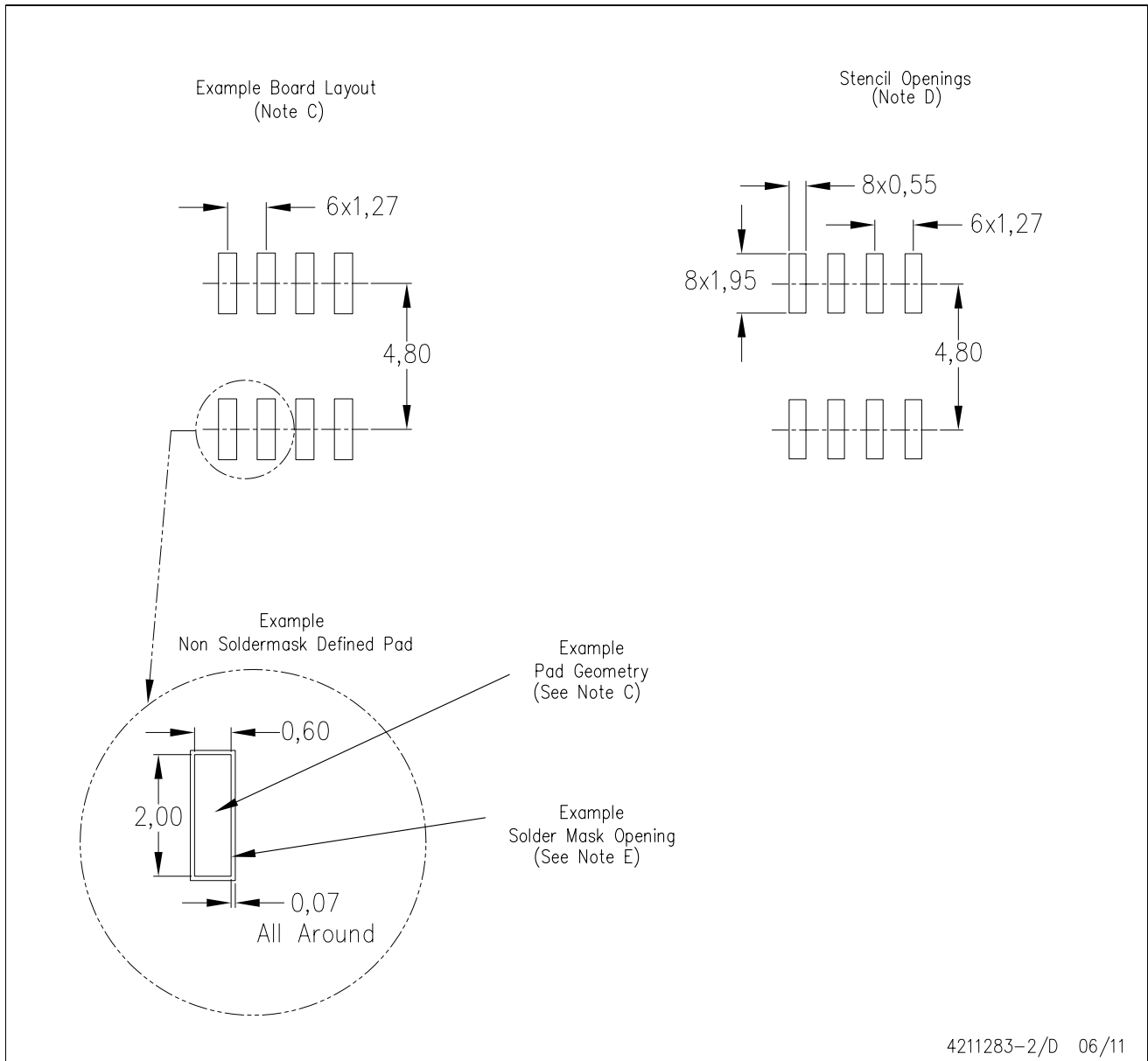

- NOTES:
- All linear dimensions are in millimeters.
 - This drawing is subject to change without notice.
 - Publication IPC-7351 is recommended for alternate designs.
 - Laser cutting apertures with trapezoidal walls and also rounding corners will offer better paste release. Customers should contact their board assembly site for stencil design recommendations. Refer to IPC-7525 for other stencil recommendations.
 - Customers should contact their board fabrication site for solder mask tolerances between and around signal pads.

IMPORTANT NOTICE

Texas Instruments Incorporated and its subsidiaries (TI) reserve the right to make corrections, modifications, enhancements, improvements, and other changes to its products and services at any time and to discontinue any product or service without notice. Customers should obtain the latest relevant information before placing orders and should verify that such information is current and complete. All products are sold subject to TI's terms and conditions of sale supplied at the time of order acknowledgment.

TI warrants performance of its hardware products to the specifications applicable at the time of sale in accordance with TI's standard warranty. Testing and other quality control techniques are used to the extent TI deems necessary to support this warranty. Except where mandated by government requirements, testing of all parameters of each product is not necessarily performed.

TI assumes no liability for applications assistance or customer product design. Customers are responsible for their products and applications using TI components. To minimize the risks associated with customer products and applications, customers should provide adequate design and operating safeguards.

TI does not warrant or represent that any license, either express or implied, is granted under any TI patent right, copyright, mask work right, or other TI intellectual property right relating to any combination, machine, or process in which TI products or services are used. Information published by TI regarding third-party products or services does not constitute a license from TI to use such products or services or a warranty or endorsement thereof. Use of such information may require a license from a third party under the patents or other intellectual property of the third party, or a license from TI under the patents or other intellectual property of TI.

Reproduction of TI information in TI data books or data sheets is permissible only if reproduction is without alteration and is accompanied by all associated warranties, conditions, limitations, and notices. Reproduction of this information with alteration is an unfair and deceptive business practice. TI is not responsible or liable for such altered documentation. Information of third parties may be subject to additional restrictions.

Resale of TI products or services with statements different from or beyond the parameters stated by TI for that product or service voids all express and any implied warranties for the associated TI product or service and is an unfair and deceptive business practice. TI is not responsible or liable for any such statements.

TI products are not authorized for use in safety-critical applications (such as life support) where a failure of the TI product would reasonably be expected to cause severe personal injury or death, unless officers of the parties have executed an agreement specifically governing such use. Buyers represent that they have all necessary expertise in the safety and regulatory ramifications of their applications, and acknowledge and agree that they are solely responsible for all legal, regulatory and safety-related requirements concerning their products and any use of TI products in such safety-critical applications, notwithstanding any applications-related information or support that may be provided by TI. Further, Buyers must fully indemnify TI and its representatives against any damages arising out of the use of TI products in such safety-critical applications.

TI products are neither designed nor intended for use in military/aerospace applications or environments unless the TI products are specifically designated by TI as military-grade or "enhanced plastic." Only products designated by TI as military-grade meet military specifications. Buyers acknowledge and agree that any such use of TI products which TI has not designated as military-grade is solely at the Buyer's risk, and that they are solely responsible for compliance with all legal and regulatory requirements in connection with such use.

TI products are neither designed nor intended for use in automotive applications or environments unless the specific TI products are designated by TI as compliant with ISO/TS 16949 requirements. Buyers acknowledge and agree that, if they use any non-designated products in automotive applications, TI will not be responsible for any failure to meet such requirements.

Following are URLs where you can obtain information on other Texas Instruments products and application solutions:

Products

Audio	www.ti.com/audio
Amplifiers	amplifier.ti.com
Data Converters	dataconverter.ti.com
DLP® Products	www.dlp.com
DSP	dsp.ti.com
Clocks and Timers	www.ti.com/clocks
Interface	interface.ti.com
Logic	logic.ti.com
Power Mgmt	power.ti.com
Microcontrollers	microcontroller.ti.com
RFID	www.ti-rfid.com
RF/IF and ZigBee® Solutions	www.ti.com/lprf

Applications

Communications and Telecom	www.ti.com/communications
Computers and Peripherals	www.ti.com/computers
Consumer Electronics	www.ti.com/consumer-apps
Energy and Lighting	www.ti.com/energy
Industrial	www.ti.com/industrial
Medical	www.ti.com/medical
Security	www.ti.com/security
Space, Avionics and Defense	www.ti.com/space-avionics-defense
Transportation and Automotive	www.ti.com/automotive
Video and Imaging	www.ti.com/video
Wireless	www.ti.com/wireless-apps

TI E2E Community Home Page

e2e.ti.com

Mailing Address: Texas Instruments, Post Office Box 655303, Dallas, Texas 75265
Copyright © 2011, Texas Instruments Incorporated